

MMSZ5221B - MMSZ5268B

V_Z : 2.4 to 82 V

P_D : 500 mW

FEATURES :

- * Total Power Dissipation 500 mW on FR-4 or FR-5 Board
- * Wide Zener Reverse Voltage Range 2.4 V to 82 V
- * Package Designed for Optimal Automated Board Assembly
- * Small Package Size for High Density Applications
- * General Purpose, Medium Current
- * Pb / RoHS Free

MECHANICAL DATA :

- * Case : SOD-123
- * Weight : 0.01 gram (approximately)

ZENER DIODES

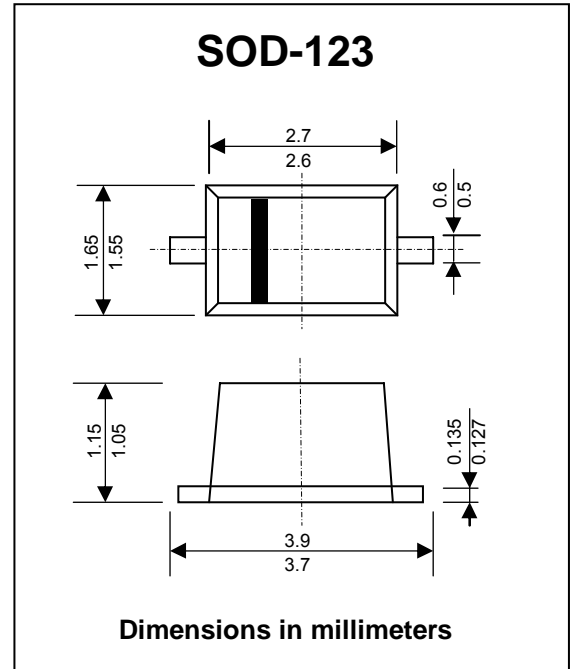

Maximum Ratings and Thermal Characteristics

Rating at 25 °C ambient temperature unless otherwise specific.

Parameter	Symbol	Value	Unit
Zener Current see Table "Characteristics"			
Total Power Dissipation on FR-5 Board, at $T_L = 75^\circ\text{C}$	P_D	500 ⁽¹⁾	mW
Derated above 75°C		6.7	mW/°C
Maximum Forward Voltage at $I_F = 10 \text{ mA}$	V_F	0.9	V
Thermal Resistance Junction to Ambient	$R_{\theta JA}$	340	°C/W
Thermal Resistance Junction to Lead	$R_{\theta JL}$	150	°C/W
Junction Temperature Range	T_J	-55 to + 150	°C
Storage Temperature Range	T_{STG}	-55 to + 150	°C

Note :

(1) FR-5 = 3.5 x 1.5 inches, using the minimum recommended footprint

ELECTRICAL CHARACTERISTICS (Ta=25 °C unless otherwise noted)

Type No.	Marking	Zener Voltage ^(1,2)			Test Current	Maximum Zener Impedance ⁽³⁾		Test Current	Maximum Reverse Leakage Current	
		V _Z @ I _{ZT} (V)				Z _{ZT} @ I _{ZT}	Z _{ZT} @ I _{ZK}		I _R @	V _R
		Min.	Nom.	Max.	I _{ZT} (mA)	(Ω)	(Ω)	I _{ZK} (mA)	(μA)	(V)
MMSZ 5221B	A4	2.28	2.4	2.52	20	30	1200	0.25	100	1.0
MMSZ 5222B	AB	2.38	2.5	2.63	20	30	1250	0.25	100	1.0
MMSZ 5223B	B4	2.57	2.7	2.84	20	30	1300	0.25	75	1.0
MMSZ 5224B	AC	2.66	2.8	2.94	20	30	1400	0.25	75	1.0
MMSZ 5225B	C4	2.85	3.0	3.15	20	29	1600	0.25	50	1.0
MMSZ 5226B	D4	3.14	3.3	3.47	20	28	1600	0.25	25	1.0
MMSZ 5227B	E4	3.42	3.6	3.78	20	24	1700	0.25	15	1.0
MMSZ 5228B	F4	3.71	3.9	4.10	20	23	1900	0.25	10	1.0
MMSZ 5229B	H4	4.09	4.3	4.52	20	22	2000	0.25	5	1.0
MMSZ 5230B	J4	4.47	4.7	4.94	20	19	1900	0.25	5	2.0
MMSZ 5231B	K4	4.85	5.1	5.36	20	17	1600	0.25	5	2.0
MMSZ 5232B	M4	5.32	5.6	5.88	20	11	1600	0.25	5	3.0
MMSZ 5233B	AD	5.70	6.0	6.30	20	7	1600	0.25	5	3.5
MMSZ 5234B	N4	5.89	6.2	6.51	20	7	1000	0.25	5	4.0
MMSZ 5235B	P4	6.46	6.8	7.14	20	5	750	0.25	3	5.0
MMSZ 5236B	R4	7.13	7.5	7.88	20	6	500	0.25	3	6.0
MMSZ 5237B	X4	7.79	8.2	8.61	20	8	500	0.25	3	6.5
MMSZ 5238B	AE	8.27	8.7	9.14	20	8	600	0.25	3	6.5
MMSZ 5239B	Y4	8.65	9.1	9.56	20	10	600	0.25	3	7.0
MMSZ 5240B	Z4	9.50	10	10.50	20	17	600	0.25	3	8.0
MMSZ 5241B	A5	10.45	11	11.50	20	22	600	0.25	2	8.4
MMSZ 5242B	B5	11.40	12	12.60	20	30	600	0.25	1	9.1
MMSZ 5243B	C5	12.35	13	13.65	9.5	13	600	0.25	0.5	9.9
MMSZ 5244B	AF	13.30	14	14.70	9.0	15	600	0.25	0.1	10
MMSZ 5245B	D5	14.25	15	15.75	8.5	16	600	0.25	0.1	11
MMSZ 5246B	E5	15.20	16	16.80	7.8	17	600	0.25	0.1	12
MMSZ 5247B	AH	16.15	17	17.85	7.4	19	600	0.25	0.1	13
MMSZ 5248B	F5	17.10	18	18.90	7.0	21	600	0.25	0.1	14
MMSZ 5249B	K9	18.05	19	19.95	6.6	23	600	0.25	0.1	14
MMSZ 5250B	H5	19.00	20	21.00	6.2	25	600	0.25	0.1	15
MMSZ 5251B	J5	20.90	22	23.10	5.6	29	600	0.25	0.1	17
MMSZ 5252B	K5	22.80	24	25.20	5.2	33	600	0.25	0.1	18
MMSZ 5253B	M9	23.75	25	26.25	5.0	35	600	0.25	0.1	19
MMSZ 5254B	M5	25.65	27	28.35	4.6	41	600	0.25	0.1	21
MMSZ 5255B	AJ	26.60	28	29.40	4.5	44	600	0.25	0.1	21
MMSZ 5256B	N5	28.50	30	31.50	4.2	49	600	0.25	0.1	23
MMSZ 5257B	P5	31.35	33	34.65	3.8	58	700	0.25	0.1	25
MMSZ 5258B	R5	34.20	36	37.80	3.4	70	700	0.25	0.1	27
MMSZ 5259B	X5	37.05	39	40.95	3.2	80	800	0.25	0.1	30
MMSZ 5260B	Y5	40.85	43	45.15	3.0	93	900	0.25	0.1	33
MMSZ 5261B	Z5	44.65	47	49.35	2.7	105	1000	0.25	0.1	36
MMSZ 5262B	A6	48.45	51	53.55	2.5	125	1100	0.25	0.1	39
MMSZ 5263B	B6	53.20	56	58.80	2.2	150	1300	0.25	0.1	43
MMSZ 5264B	AK	57.00	60	63.00	2.1	170	1400	0.25	0.1	46
MMSZ 5265B	C6	58.90	62	65.10	2.0	185	1400	0.25	0.1	47
MMSZ 5266B	D6	64.60	68	71.40	1.8	230	1600	0.25	0.1	52
MMSZ 5267B	E6	71.25	75	78.75	1.7	270	1700	0.25	0.1	56
MMSZ 5268B	F6	77.90	82	86.10	1.5	330	2000	0.25	0.1	62

Notes :

- (1) The type numbers shown have a standard tolerance of ± 5% on the nominal Zener voltage.
- (2) Nominal Zener voltage is measured with the device junction in thermal equilibrium at T_L = 30°C ± 1°C
- (3) Z_{ZT} and Z_{ZK} are measured by device drop across the device by the AC current apply
The specified limits are for I_{Z(AC)} = 0.1 I_{Z(DC)} with the AC frequency 1 KHz